

HOCHIKI YBO-BSB BASE SOUNDER BEACON INSTALLATION INSTRUCTIONS



Products Covered: YBO-BSB installed with ALG-E, ALG-E(NP), AIE-E, AIE-E(NP), ATG-E, ATG-E(NP), ACA-E, ACB-E Sensors, CHQ-AB Range of Beacons, CHQ-ARI Remote Indicator and YBN-R/3 Standard Base, YBO-R/SCI Short-Circuit Isolator Base (from batch code 6044 only).

Introduction

The Loop-Powered Base Sounder Beacon (YBO-BSB) is designed to complement the standard common mounting base (YBN-R/3) and the isolator base (YBO-R/SCI) in locations where Loop-Powered Sounders and Beacons are required. The YBO-BSB has connections for both of these types of base as well as for the standard range of Hochiki Analogue Addressable Sensors and Beacons. The YBO-BSB is designed to give audible and visual alerts in locations such as Hotel Bedrooms, Offices and Corridors. Note that the YBO-BSB is for indoor use only (Type A) and is rated at IP21.

Common Configurations

The YBO-BSB can be used in conjunction with an ESP Sensor, Beacon or Remote Indicator (see Fig.1) or with the addition of a Cap (see Fig. 2).

Address Setting

The default address of the YBO-BSB is 254, and therefore if the YBO-BSB is to be used as a base sounder (sensor on top) then the address will not need to be changed, as the control panel will automatically address the sounder as described below. However, if the sounder is to be used as a wall sounder then the YBO-BSB will need to be manually addressed from 1 to 127 as described below. **Note: Control Panel compatibility needs to be checked to verify if automatic addressing above 127 is supported.**

Automatic Addressing (Control Panel)

The control panel automatically assigns the address to the base sounder at initialisation, the address is calculated by taking the address of the sensor that is fitted to the base sounder and adding 127, this is then stored within the base sounder. For example, if a sensor is set at address 10 then the base sounder would be automatically set at address 137. Addresses above 127 may not be visible to the user depending upon the implementation by the Control Panel.

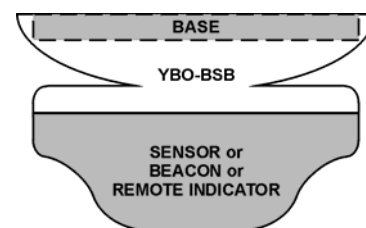

Fig. 1

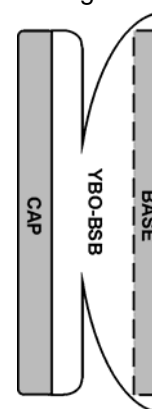

Fig. 2

Manual Addressing (Hand Held Programmer)

The base sounder address can be set using the Hand Held programmer (TCH-B100) from 1 to 254. See the TCH-B100 instructions for further details of address setting. If the YBO-BSB is to be used as a wall sounder then the address should be set from 1 to 127 before being installed. If the YBO-BSB is to be used as a base sounder (sensor on top) then the address should be set from 128 to 254.

Precautions

- Ensure that the base sounder is installed in accordance with Local Standards or Regulations.
- Check that both sensor and mounting base are compatible with the YBO-BSB.
- Only install in suitable environments, the following in particular should be avoided: -
 - Excessive ambient temperature.
 - Where excessive condensation or moisture is present.
 - Hazardous areas.
- A high voltage tester must not be used with this base sounder.
- Ensure that the base sounder is securely fixed to the mounting base.
- For proper wiring supervision ensure that the cables are wired as shown in the diagram below.

Tones and Volumes

Table 1 below shows the full range of sound outputs available from the YBO-BSB and the amount of current drawn when operated. When the YBO-BSB is selected to be a base sounder (sensor on top) the default sound output will be 85dB(A). The YBO-BSB is also capable of utilising a number of different EN54-3 Approved tones. A total of 51 tones are available, these are listed in Table 2 and in document AP092 available from our web site. **The tone of the sounder and the volume level is selected and controlled by the control panel, therefore check with the control panel manufacturer for options and default values available.**

Table 1	
Nominal Sound Output dB(A) ^{*1 *2}	Current Drawn mA ^{*3}
50	0.8
55	0.8
60	0.8
70	0.8
78	1.5
80	2.0
85	3.0
88	4.5
90	6.5
93	8.0
94	10
95	11
98	16

*1 @ 1m distance

*2 Refer to AP092 (available from our website) for complete EN54-A-weighted sound levels

*3 An additional 5mA will be drawn when beacon is activated

Locking Mechanism

The base sounder can be locked onto the relevant mounting base by removing a plastic lug on the underside of the sounder (see Fig. 3).

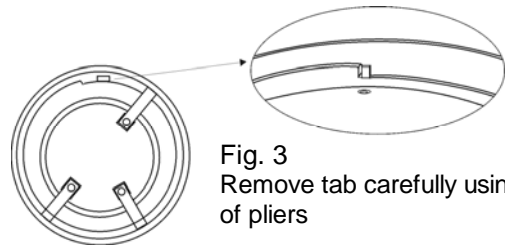

Fig. 3 Remove tab carefully using a pair of pliers

The sounder can then only be removed by using a special Removal Tool (TSC-SRT), which is available from Hochiki Europe (UK) Ltd.

Installation

The base sounder is designed to be mounted on the Standard Mounting Base (YBN-R/3) or the Short-Circuit Isolator Mounting Base (YBO-R/SCI, from batch code 6044 only) in the same method as a Sensor. The terminals on the mounting base hold the YBO-BSB and in turn the terminals on the YBO-BSB hold the sensor, beacon or cap if being used as a wall sounder (see below). For correct wiring of the appropriate mounting base, please refer to the diagram below.

Using the YBO-BSB as a Wall Sounder Beacon

A push-fit cap (SI/CAP) is available to cover the electrical connections if an analogue sensor, beacon or indicator is not being fitted (see Fig. 2). Align the arrow marked inside the cap with the sensor alignment mark on the base sounder. This will ensure the four tabs on the cover will engage with the matching slots in the base sounder. Push cap firmly onto the base sounder until it clicks into place.

Wiring

Please refer to Fig. 4 for wiring the Standard Mounting Base (YBN-R/3) and the Short-Circuit Isolator Mounting Base (YBO-R/SCI):

- A: Loop (+)
- B: Loop (-)
- C: Cable Screen (where used)

Operating Voltage:
17 ~ 41 Vd.c.

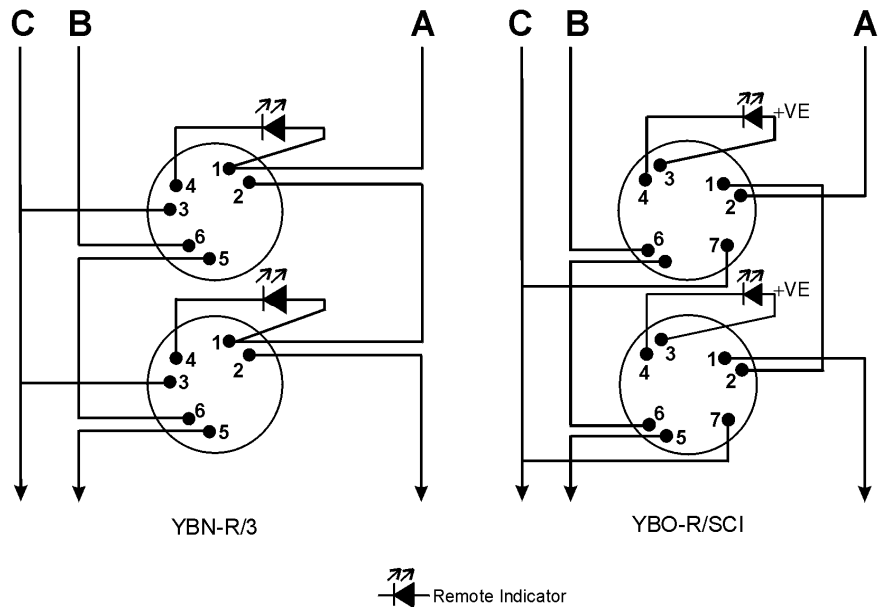

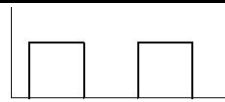
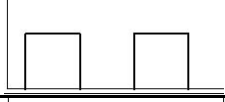
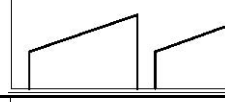
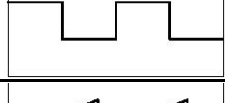
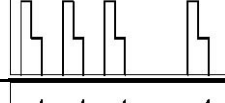

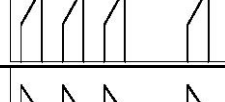
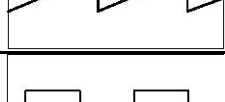
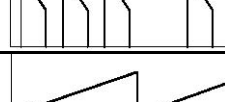
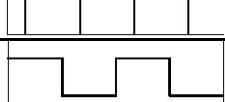



Fig. 4

Table 2

Tone Number	Tone Description	Graphic Representation	Tone Number	Tone Description	Graphic Representation
0	Sounder Off		19	800 Hz : 250 ms 970 Hz : 250 ms	
1	925 Hz : 250 ms 628 Hz : 250 ms		20	2850 Hz Continuous	
2	925 Hz Continuous		21	2400 Hz : 250 ms 2850 Hz : 250 ms	
3	628 Hz Continuous		22	800 Hz : 500 ms 970 Hz : 500 ms	
4	(French) 554 Hz : 100 ms 440 Hz : 400 ms		23	2850 Hz : 500 ms Off : 500 ms	
5	(Swedish) 660 Hz : 150 ms Off : 150 ms		24	925 Hz : 250 ms Off : 1000 ms	
6	925 Hz : 150 ms Off : 600 ms		25	970 Hz Continuous	
7	670 Hz : 250 ms 845 Hz : 370 ms		26	660 Hz : 1800 ms Off : 1800 ms	
8	Whoop 500 Hz - 1200 Hz 3000 ms Off : 500 ms		27	660 Hz : 6500 ms Off : 13000 ms	
9	1200 Hz : 500 ms 500 Hz : 500 ms		28	660 Hz Continuous	
10	970 Hz : 500 ms Off : 500 ms		29	554 Hz : 500 ms 440 Hz : 500 ms	
11	Sweep 800 Hz - 970 Hz over 140 ms (7 Hz)		30	660 Hz : 500 ms Off : 500 ms	
12	Sweep 800 Hz - 970 Hz over 1000 ms (1 Hz)		31	2850 Hz : 150 ms Off : 100 ms	
13	Sweep 800 Hz - 970 Hz over 20 ms (50 Hz)		32	Sweep 2400 Hz - 2850 Hz over 20 ms (50 Hz)	
14	Sweep 2400 Hz - 2850 Hz over 140 ms (7 Hz)		33	Sweep 800 Hz - 970 Hz over 500 ms (2 Hz)	
15	Sweep 2400 Hz - 2850 Hz over 1000 ms (1 Hz)		34	988 Hz : 250 ms 645 Hz : 250 ms	
16	Sweep 300 Hz - 1200 Hz over 1000 ms (1 Hz)		35	510 Hz : 250 ms 610 Hz : 250 ms	
17	ISO8201 : 970 Hz : 500 ms		36	Sweep 800 Hz - 970 Hz over 110 ms (9 Hz)	
18	ISO8201 : 2850 Hz : 500 ms		37	Sweep 800 Hz - 970 Hz over 330 ms (3 Hz)	

Tone Number	Tone Description	Graphic Representation	Tone Number	Tone Description	Graphic Representation
38	845 Hz Continuous		46	440 Hz : 600 ms Off : 600 ms	
39	970 Hz : 1000 ms Off : 1000 ms		47	Whoop 500 Hz – 1200 Hz : 3750 ms Off : 250 ms	
40	800 Hz : 150 ms 970 Hz : 150 ms		48	ISO8201 925 Hz, 628 Hz : 250 ms Off 500 ms	
41	Sweep 2400 Hz – 2850 Hz over 110 ms (9 Hz)		49	ISO8201 : Sweep 300 Hz – 1200 Hz : 500 ms Off : 500 ms	
42	Sweep 2400 Hz – 2850 Hz over 330 ms (3 Hz)		50	ISO8201 : Sweep 1200 Hz – 300 Hz : 500 ms Off : 500 ms	
43	2850 Hz : 1000 ms Off : 1000 ms		51	Whoop 500-1200 3.5s/0.5s	
44	2400 Hz : 150 ms 2850 Hz : 150 ms				
45	(German) Whoop 1200 Hz – 500 Hz : 1000ms Off : 10 ms	