



HOCHIKI WALL SOUNDER INSTALLATION INSTRUCTIONS

Products Covered: CHQ-WS2 Wall Sounder, YBO-R/3(RED) Standard Base, YBO-R/SCI(RED) Isolator Base.

Introduction

The CHQ-WS2 is a loop-powered addressable wall sounder designed to be compatible with the standard red mounting base (YBO-R/3(RED)) and the red isolator base (YBO-R/SCI(RED)); the CHQ-WS2 has connections for both these types of base. Do not attempt to use any other base type with this sounder.

The CHQ-WS2 is Ingress Protection rated to IP21 for internal use, but can be made weatherproof when used in conjunction with the WS2-WPK Weather Proofing Kit, in which case it is Ingress Protection rated to IP65* but only when used in accordance with the WS2-WPK instructions (2-3-0-627).

Address Setting (with Hand Held Programmer)

The CHQ-WS2 will need to be manually addressed between 1 and 127. The sounder address can be set using the Hand Held programmer (TCH-B100) as the unit includes the appropriate terminals to fit directly onto the Programmer. See the TCH-B100 instructions for further details of address setting. The address must be set before installation.

Tones and Volumes

Table 1 below shows the full range of sound outputs available from the CHQ-WS2 together with the amount of current drawn when operated. The sounder is also capable of utilising a number of different EN54-3 Approved tones; these are listed in Table 2, page 3. **The tone of the sounder and the volume level is selected and controlled by the control panel, therefore check with the control panel manufacturer for options and default values available.**

Nominal Sound Output dB(A)* †	Current Drawn mA
90	2.0
95	3.0
98	4.5
100	6.5
102	8.0

* Refer to AP084 (available from our website) for complete EN54-3 A-weighted sound levels.

† @ 1m distance.

Precautions

- ❑ Ensure that the wall sounder is installed in accordance with Local Standards or Regulations.
- ❑ Only use the specified Hochiki mounting bases (or WS2-WPK Weather Proofing Kit) with this wall sounder.
- ❑ Only install in suitable environments, the following in particular should be avoided: -
 - Excessive ambient temperature.
 - Where excessive condensation or moisture is present (unless WS2-WPK is utilised).
 - Hazardous areas.
- ❑ A high voltage tester must not be used with this wall sounder or either of the specified bases.
- ❑ Ensure that the wall sounder is securely fixed to the mounting base (and WS2-WPK if utilised).
- ❑ For proper wiring supervision ensure that the cables are wired as shown in Fig 4.

* This product has only been approved to IP33 by LPCB

Locking Mechanism

The wall sounder can be locked onto the relevant mounting base by removing a plastic lug on the underside of the sounder, refer to Fig. 1

The sounder can then only be removed from the base by using a special removal tool, TSE-SRT, which is available from Hochiki Europe (UK) Ltd.

Remove tab carefully using a pair of pliers.

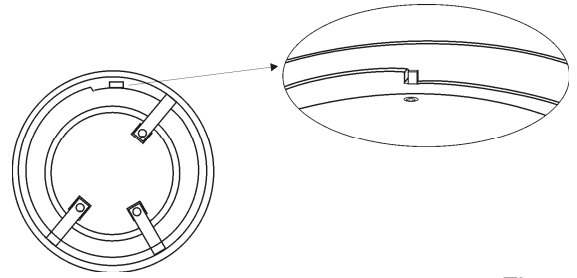

Fig. 1

Installation

The CHQ-WS2 sounder is designed to be mounted directly onto the Red Standard Mounting Base (YBO-R/3(RED)) or the Red Short-Circuit Isolator Mounting Base (YBO-R/SCI(RED)) in the same method as a Sensor (see Fig. 2). The terminals on the mounting base hold the CHQ-WS2 in place.

Fix the mounting base to the required surface using appropriate fixings. For correct wiring of the each base type, refer to Fig. 4.

When installing the CHQ-WS2 in exterior locations use the WS2-WPK Weather Proofing Kit. The kit consists of a weatherproof back box and two gaskets, which must be used in conjunction with either mounting base to maintain the IP rating (see Fig. 3). For further information, refer to the WS2-WPK Weather Proofing Kit instructions (2-3-0-627).

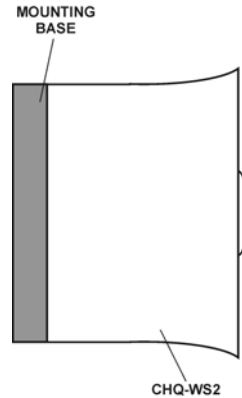

Fig. 2

Wiring

Please refer to the following diagram for wiring the Red Standard Mounting Base (YBO-R/3(RED)) and the Red Short-Circuit Isolator Mounting Base (YBO-R/SCI(RED)):

Key: A: Loop (+) B: Loop (-) C: Cable Screen

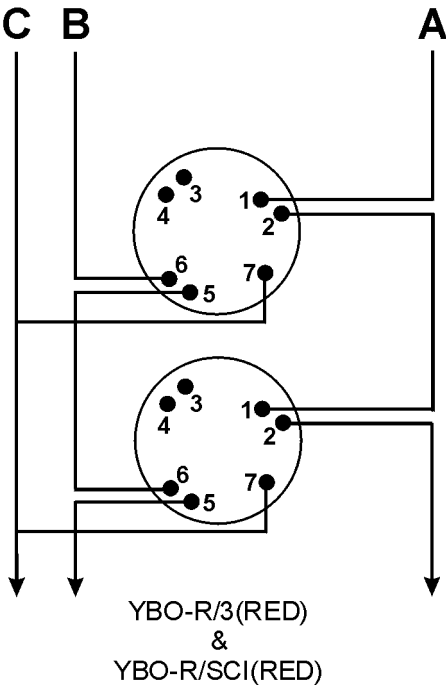

Fig. 4

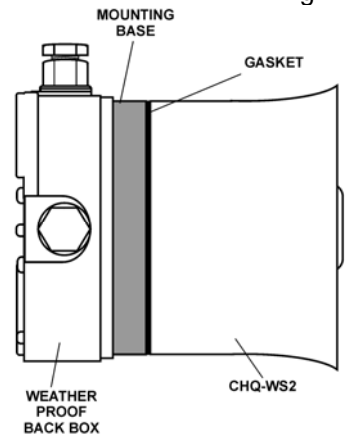

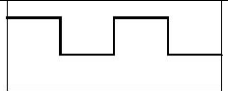
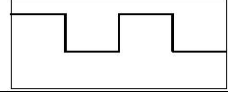
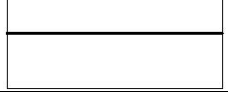
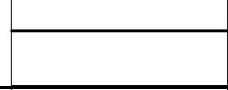
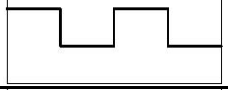
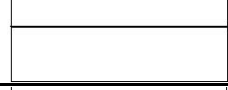
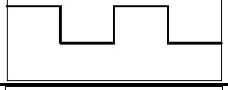
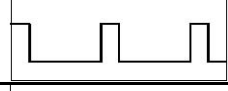
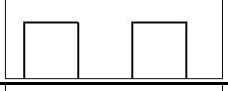
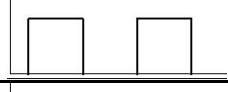

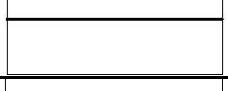
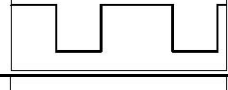
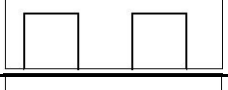

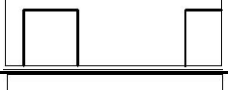
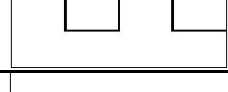
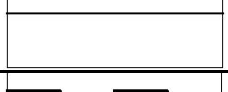
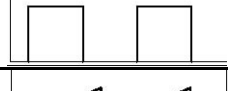

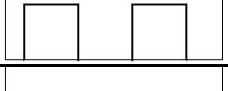

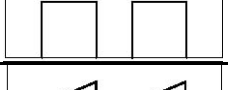



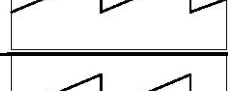







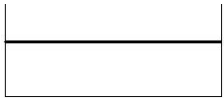
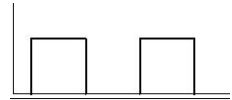
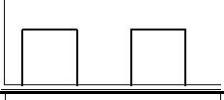
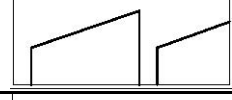

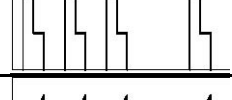

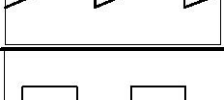
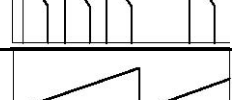
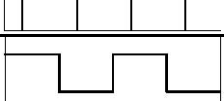



Fig. 3

CHQ-WS2 Operating Voltage 17 ~ 41 Vd.c.

Table 2					
Tone Number	Tone Description	Graphic Representation	Tone Number	Tone Description	Graphic Representation
0	Sounder Off		19	800 Hz : 250 ms 970 Hz : 250 ms	
1	925 Hz : 250 ms 628 Hz : 250 ms		20	2850 Hz Continuous	
2	925 Hz Continuous		21	2400 Hz : 250 ms 2850 Hz : 250 ms	
3	628 Hz Continuous		22	800 Hz : 500 ms 970 Hz : 500 ms	
4	(French) 554 Hz : 100 ms 440 Hz : 400 ms		23	2850 Hz : 500 ms Off : 500 ms	
5	(Swedish) 660 Hz : 150 ms Off : 150 ms		24	925 Hz : 250 ms Off : 1000 ms	
6	925 Hz : 150 ms Off : 600 ms		25	970 Hz Continuous	
7	670 Hz : 250 ms 845 Hz : 370 ms		26	660 Hz : 1800 ms Off: 1800 ms	
8	Whoop 500 Hz - 1200 Hz 3000 ms Off : 500 ms		27	660 Hz : 6500 ms Off : 13000 ms	
9	1200 Hz : 500 ms 500 Hz : 500 ms		28	660 Hz Continuous	
10	970 Hz : 500 ms Off : 500 ms		29	554 Hz : 500 ms 440 Hz : 500 ms	
11	Sweep 800 Hz - 970 Hz over 140 ms (7 Hz)		30	660 Hz : 500 ms Off : 500 ms	
12	Sweep 800 Hz - 970 Hz over 1000 ms (1 Hz)		31	2850 Hz : 150 ms Off : 100 ms	
13	Sweep 800 Hz - 970 Hz over 20 ms (50 Hz)		32	Sweep 2400 Hz – 2850 Hz over 20 ms (50 Hz)	
14	Sweep 2400 Hz – 2850 Hz over 140 ms (7 Hz)		33	Sweep 800 Hz – 970 Hz over 500 ms (2 Hz)	
15	Sweep 2400 Hz – 2850 Hz over 1000 ms (1 Hz)		34	988 Hz : 250 ms 645 Hz : 250 ms	
16	Sweep 300 Hz – 1200 Hz over 1000 ms (1 Hz)		35	510 Hz : 250 ms 610 Hz : 250 ms	
17	ISO8201 : 970 Hz : 500 ms		36	Sweep 800 Hz – 970 Hz over 110 ms (9 Hz)	
18	ISO8201 : 2850 Hz : 500 ms		37	Sweep 800 Hz – 970 Hz over 330 ms (3 Hz)	

Tone Number	Tone Description	Graphic Representation	Tone Number	Tone Description	Graphic Representation
38	845 Hz Continuous		46	440 Hz : 600 ms Off : 600 ms	
39	970 Hz : 1000 ms Off : 1000 ms		47	Whoop 500 Hz – 1200 Hz : 3750 ms Off : 250 ms	
40	800 Hz : 150 ms 970 Hz : 150 ms		48	ISO8201 925 Hz, 628 Hz : 250 ms Off 500 ms	
41	Sweep 2400 Hz – 2850 Hz over 110 ms (9 Hz)		49	ISO8201 : Sweep 300 Hz – 1200 Hz : 500 ms Off : 500 ms	
42	Sweep 2400 Hz – 2850 Hz over 330 ms (3 Hz)		50	ISO8201 : Sweep 1200 Hz – 300 Hz : 500 ms Off : 500 ms	
43	2850 Hz : 1000 ms Off : 1000 ms		51	Whoop 500-1200 3.5s/0.5s	
44	2400 Hz : 150 ms 2850 Hz : 150 ms				
45	(German) Whoop 1200 Hz – 500 Hz : 1000ms Off : 10 ms	