

MOUNTING ADAPTORS

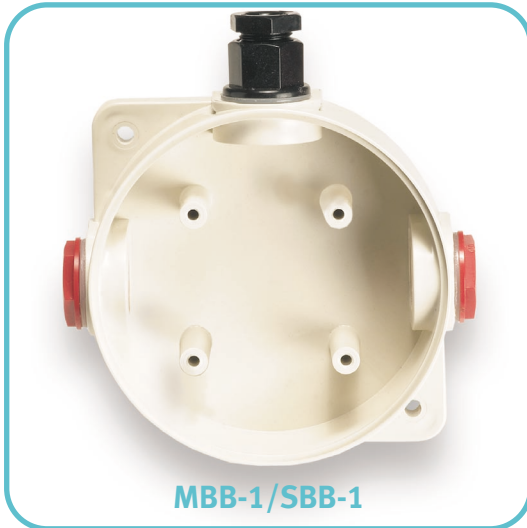

MBB-1/SBB-1

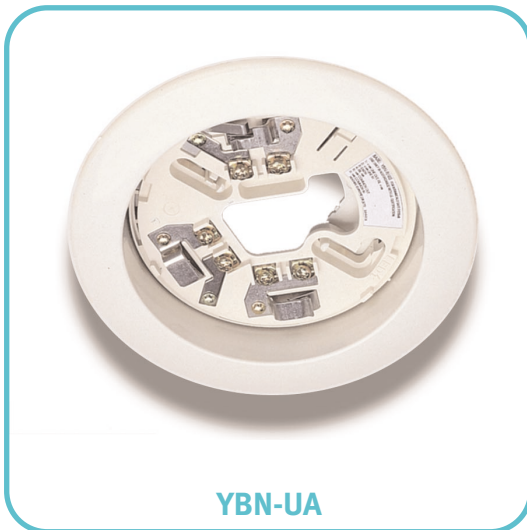

YBN-UA



YBD-RA

Hochiki's range of mounting adaptors allows both the ESP and CDX range of sensors/ detectors to be mounted onto a variety of fixing surfaces:

MBB-1 Marine Back Box

The approved design of the MBB-1 provides a splash proof and secure fixing for the Hochiki CDX Marine Approved Range of Detectors and their associated Bases.

- ▶ Glanded cable entry holes
- ▶ Colour matched
- ▶ Approved sensor and base range
- ▶ Provides moisture and dust resistant fixing
- ▶ Ideal for bulk-head fixing
- ▶ Approved by Lloyds, DNV & Germanischer Lloyd
- ▶ Non-marine use version available (SBB-1)

YBN-UA Recess Adaptor

The YBN-UA is a Recess Base adaptor which allows detectors/sensors to be flush mounted.

- ▶ Easy to install
- ▶ Colour matched
- ▶ Tested by LPCB

YBD-RA Surface Wiring Adaptor

The YBD-RA Surface Wiring Adaptor allows the majority of sensors/detectors and their Mounting Bases to be fitted flush against a fixing surface whilst also allowing surface wiring (without conduit) to be connected.

- ▶ 4 pre-moulded knock-outs provide wiring entry
- ▶ Low profile - only 16mm
- ▶ Colour matched

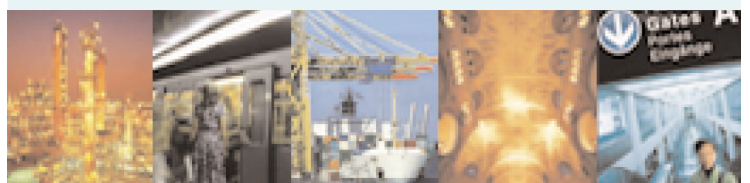

DIMENSIONS

YBN-UA

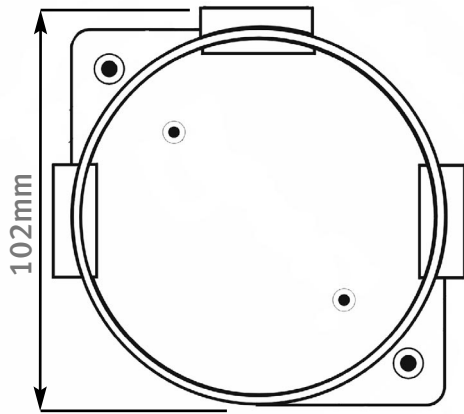
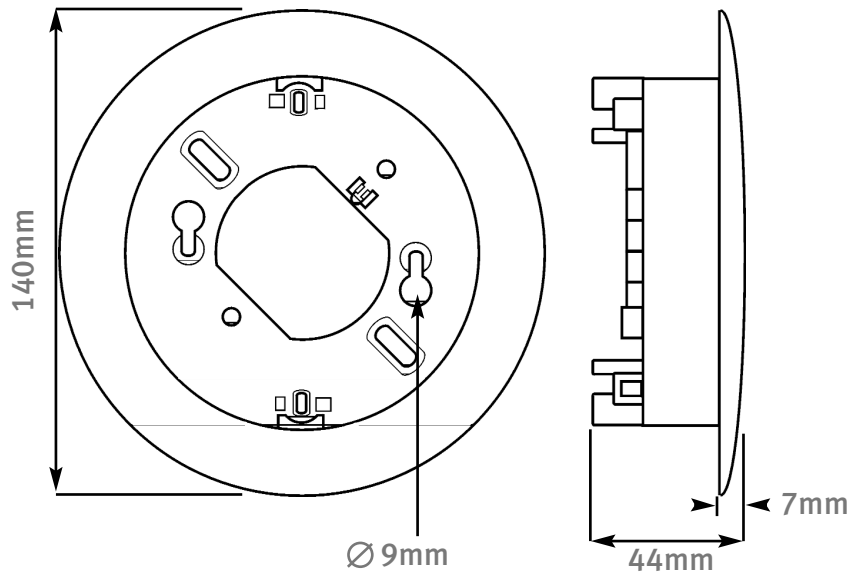

MBB-1/SBB-1

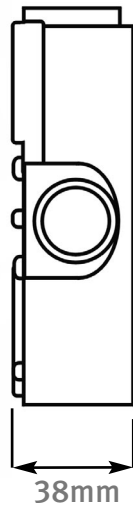

YBD-RA



16mm

SPECIFICATIONS

Ordering Codes	MBB-1/SBB-1	YBN-UA	YBD-RA
Maximum Humidity		95%RH - Non Condensing (at 40°C)	
Colour / Case Material		Ivory White / ABS	
Weight (g)	123	65	27
Compatible Bases	YBN-R/3, YBN-R/4M, YBN-R/6, YBN-R/6SK, YBO-R/5M, YBO-R/6, YBO-R/6, YBO-R/6RN, YBO-R/6RS, YBO-R/6PA, ACB-EW Mounting Base (MBB-1/SBB-1 will also accept the Waterproof Heat Detector DFG-60E - no base required)		
Base Fixing Centres (mm)	116	48 ~ 74	61 ~ 89
Approvals	Lloyds	✓ (MBB-1 only)	
	DNV	✓ (MBB-1 only)	
	Germanischer Lloyd	✓	
	LPCB	✓	

HOCHIKI EUROPE (UK) LIMITED
 Grosvenor Road, Gillingham Business Park,
 Gillingham, Kent, England ME8 0SA
 Telephone: +44 (0)1634 260133
 Facsimile: +44 (0)1634 260132
 e-mail (UK): sales@hochikieurope.com
 e-mail (Non UK): export@hochikieurope.com
 www.hochikieurope.com



Quality System
 Certificate No. 164
 Assessed to ISO9001



Environmental Management System
 Certificate No. EMS 286
 Assessed to ISO 14001 : 1996

PART No. 9-5-0-266/ISS2/JUL05