

## POWER SUPPLY UNITS



HE-PSU(1.25)



HE-PSU(2.5) & HE-PSU(4.0)



The HE-PSU Range of standalone power supply units have been specifically designed to maintain a system's integrity by providing the ability to function for long periods of time during extended failure of the primary or mains supply.

The units are housed in robust, key-lockable enclosures and are suitable for a wide range of uses with three output variants available - 1.25A, 2.5A and 4.0A. They can be used in conjunction with the FIRElink range of air sampling detectors and those 'Smart-Fix' CHQ Modules that are not loop-powered and require an auxiliary 24Vd.c. power supply (CHQ-DZM Dual Zone Monitor and CHQ-DSC Dual Sounder Controller).

Space is also provided for the provision of back-up batteries.

- ▶ Three output variants - 1.25A, 2.5A and 4.0A
- ▶ Full monitoring of mains failure, battery disconnection and total power failure
- ▶ Robust, fully welded cabinet design with key lock
- ▶ Range of charging capacities



## DIMENSIONS

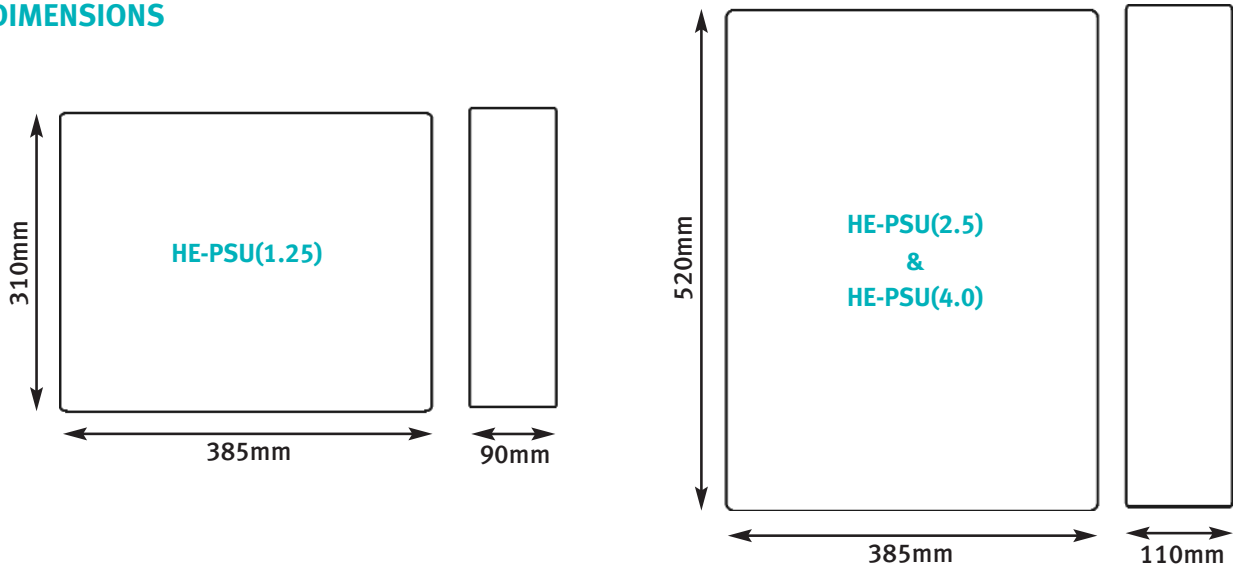

## WIRING

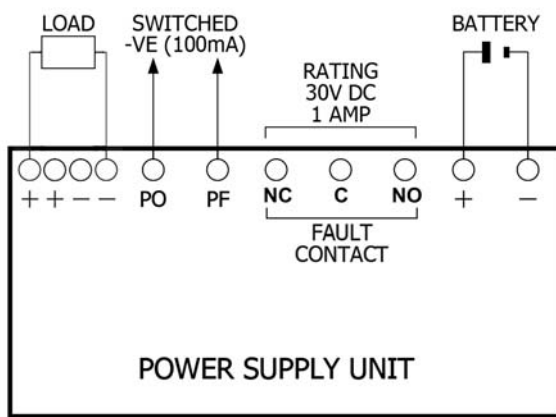

HE-PSU(1.25)

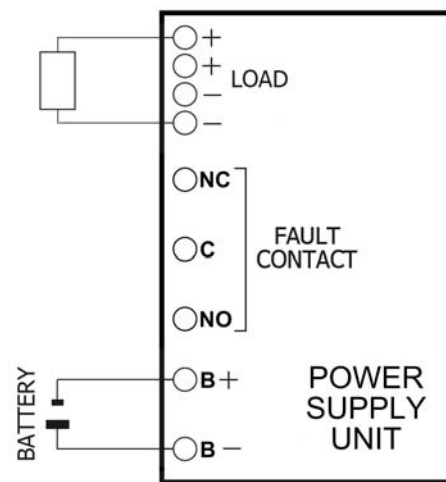

HE-PSU(2.5) & HE-PSU(4.0)

## SPECIFICATION

Ordering Codes	HE-PSU(1.25)	HE-PSU(2.5)	HE-PSU(4.0)
Output	1.25A	2.5A	4.0A
Supply Voltage		230V a.c. (+10%/-15%)	
Load Voltage (approx)		28V	
Battery Voltage		27.6V d.c.	
Output Ripple/Noise		0.5V (at full load)	
Fault Output		Switched -VE and volt free contacts	
Operating Temperature Range		-10°C to + 50°C	
Accepted Battery Size	7Ah	17Ah	17Ah
Case Colour		RAL 7042 ("Traffic Grey A")	
Case Material		1.2mm fully welded sheet steel	
Standard Max Charging (in 24hrs)	4.0Ah	12.0Ah	15.0Ah
Weight without batteries (Kg)	7.5 approx	8.5 approx	9.0 approx

**HOCHIKI EUROPE (UK) LIMITED**  
 Grosvenor Road, Gillingham Business Park,  
 Gillingham, Kent, England ME8 0SA  
 Telephone: +44 (0)1634 260133  
 Facsimile: +44 (0)1634 260132  
 e-mail (UK): sales@hochikieurope.com  
 e-mail (Non UK): export@hochikieurope.com  
 www.hochikieurope.com



PART No. 9-5-0-389/ISS1/JUN08

Hochiki Europe (UK) Ltd. reserves the right to alter the specification of its products from time to time without notice. Although every effort has been made to ensure the accuracy of the information contained in this document it is not warranted or represented by Hochiki Europe (UK) Ltd. to be a complete and up-to-date description.