

## ANALOGUE BEACONS AND INDICATOR



CHQ-AB(RED)



CHQ-AB(AMB) & CHQ-AB(BLU)



CHQ-ARI(CLR)

All Beacon models are fully compatible with Hochiki's ESP analogue addressable protocol.

Each unit is fitted with a Fresnel lens and high-intensity LEDs, a design which produces a highly visible flash. The casing exactly matches the Hochiki ESP Sensor range in shape and colour providing seamless integration.

Choose from three different lens colours: CHQ-AB(RED) featuring a red lens, CHQ-AB(BLU) featuring a blue lens and CHQ-AB(AMB) featuring an amber lens.

- ▶ Variable flash frequency
- ▶ Addressable via the TCH-B100 Hand Held Programmer
- ▶ Compatible with all Hochiki Analogue Addressable Bases including the Base Sounder (CHQ-BS)



Model CHQ-ARI(CLR) is an addressable Remote Indicator, producing a continuous illumination through a transparent (uncoloured) lens.

- ▶ High-intensity illumination via red-coloured LEDs
- ▶ Addressable via the TCH-B100 Hand Held Programmer

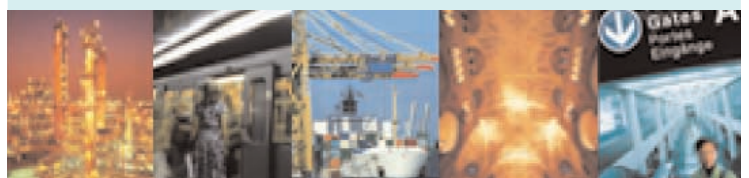

## DIMENSIONS

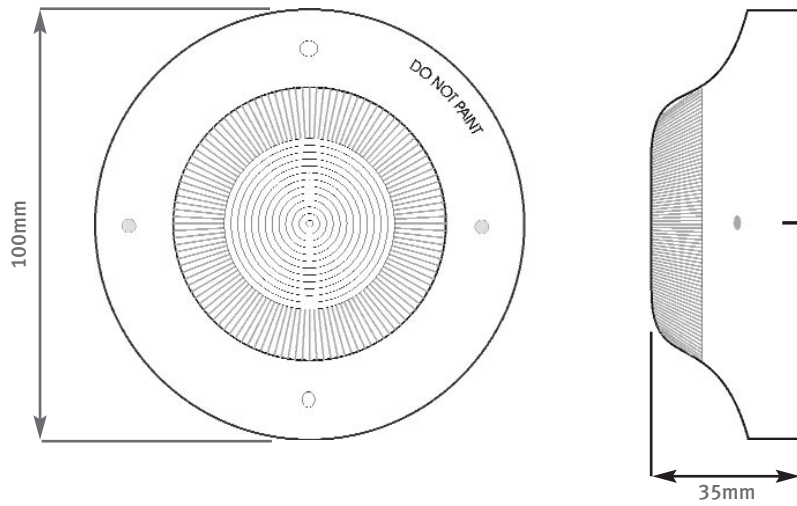

CHQ-AB & CHQ-ARI (all variants)

## WIRING

KEY: A Loop +ve, B Loop -ve, C Cable Screen

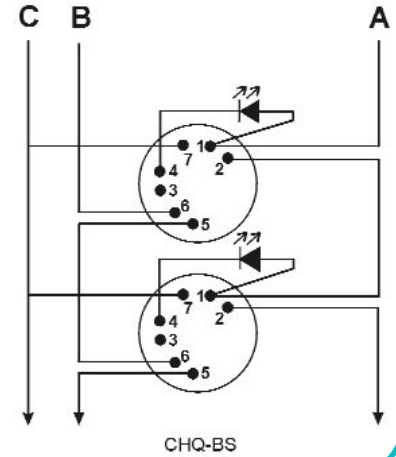
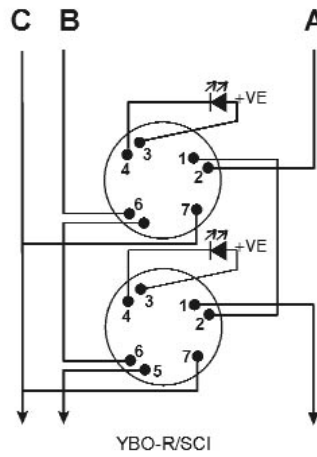
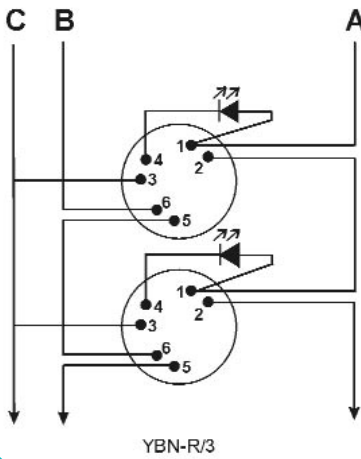

## SPECIFICATIONS

Ordering Code/Lens Colour	CHQ-AB(RED)/Transparent Red CHQ-AB(AMB)/Transparent Amber CHQ-AB(BLU)/ Transparent Blue
Operating Voltage	17 - 41Vdc
Quiescent Current (typ)	240µA (300µA max)
Operating Current (typ)	4.3mA (5.0mA max)
Operating Temperature Range	-10°C to + 50°C
Storage Temperature Range	-30°C to + 60°C
Maximum Humidity	95%RH - Non Condensing (at 40°C)
Ingress Protection Rating	IP42
Colour / Case Material	Ivory White / ABS
Weight (g)	88
Compatible Bases	YBN-R/3, CHQ-BS, YBO-R/SCI
Base Fixing Centres (mm)	48 ~ 74

Ordering Code/Lens Colour	CHQ-ARI(CLR)/Transparent
Operating Voltage	17 - 41Vdc
Quiescent Current (typ)	280µA (300µA max)
Operating Current (typ)	4.5mA to 5.4mA
Operating Temperature Range	-10°C to + 50°C
Storage Temperature Range	-30°C to + 60°C
Maximum Humidity	95%RH - Non Condensing (at 40°C)
Ingress Protection Rating	IP42
Colour / Case Material	Ivory White / ABS
Weight (g)	88
Compatible Base	YBN-R/3, CHQ-BS, YBO-R/SCI
Base Fixing Centres (mm)	48 ~ 74

**HOCHIKI EUROPE (UK) LIMITED**  
Grosvenor Road, Gillingham Business Park,  
Gillingham, Kent, England ME8 0SA  
Telephone: +44 (0)1634 260133  
Facsimile: +44 (0)1634 260132  
e-mail (UK): sales@hochikieurope.com  
e-mail (Non UK): export@hochikieurope.com  
www.hochikieurope.com



Quality System  
Certificate No. 164  
Assessed to ISO9001

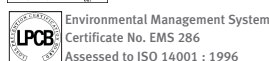

Environmental Management System  
Certificate No. EMS 286  
Assessed to ISO 14001 : 1996

Hochiki Europe (UK) Ltd. reserves the right to alter the specification of its products from time to time without notice. Although every effort has been made to ensure the accuracy of the information contained in this document it is not warranted or represented by Hochiki Europe (UK) Ltd. to be a complete and up-to-date description.

PART No. 9-5-0-274/ISS1/JAN05