

## DOOR RETAINER



Model DR-24 is an electromagnetic door retainer which ensures retention of the door by means of a smart metallic keeper plate.

It is designed to hold open fire doors and is ideally suited for hospitals, schools and other public buildings.

In a fire situation the doors can be released automatically via a connection to the fire alarm system or manually by activating the release button.

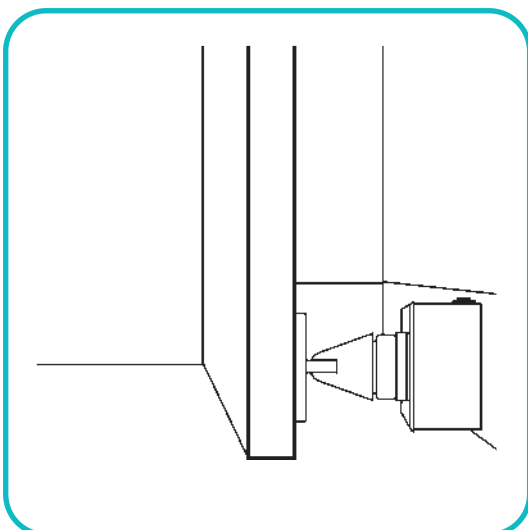

- ▶ 24Vdc
- ▶ Surface mounted
- ▶ 200 Newton holding force
- ▶ Swivel keeper plate
- ▶ Spring-loaded ejector pin
- ▶ Manual release button

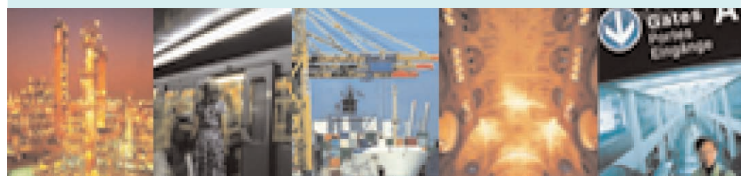

## DIMENSIONS

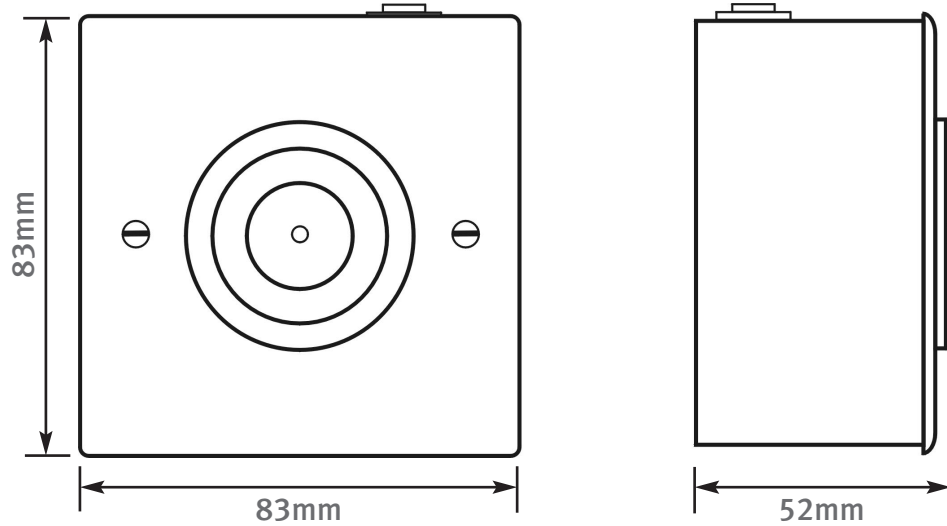

## WIRING

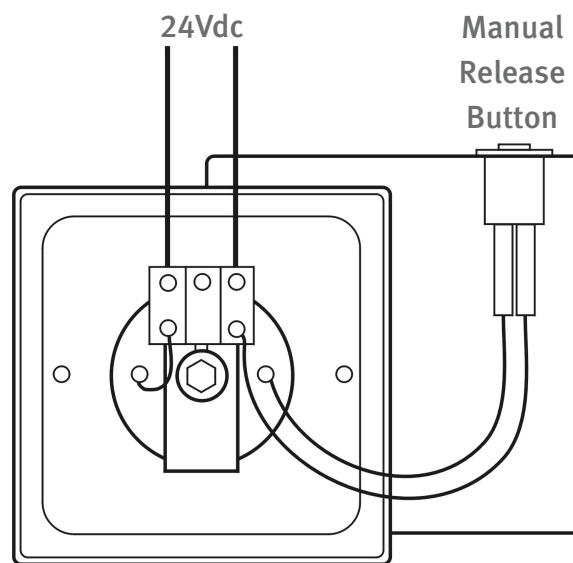

## SPECIFICATION

Ordering Code	DR-24
Operating Voltage Range	20.4 -27.6Vdc
Nominal Current	30mA
Nominal Power (at 20°C)	0.6W
Holding Force	200N
Operating Temperature Range	0°C to +40°C
Weight (g)	(Back Box) 42 / H83 x W83 x D52
	(Swivel Keeper Plate) 12 / H55 x W55 x D52
IP Rating	IP54

**HOCHIKI EUROPE (UK) LIMITED**  
Grosvenor Road, Gillingham Business Park,  
Gillingham, Kent, England ME8 0SA  
Telephone: +44 (0)1634 260133  
Facsimile: +44 (0)1634 260132  
e-mail (UK): sales@hochikieurope.com  
e-mail (Non UK): export@hochikieurope.com  
www.hochikieurope.com



Environmental Management System  
Certificate No. EMS 286  
Assessed to ISO 14001 : 1996



Environmental Management System  
Certificate No. EMS 286  
Assessed to ISO 14001 : 1996

Hochiki Europe (UK) Ltd. reserves the right to alter the specification of its products from time to time without notice. Although every effort has been made to ensure the accuracy of the information contained in this document it is not warranted or represented by Hochiki Europe (UK) Ltd. to be a complete and up-to-date description.

PART No. 9-5-0-264/ISS1/OCT04