

PHOTOELECTRIC SMOKE SENSOR

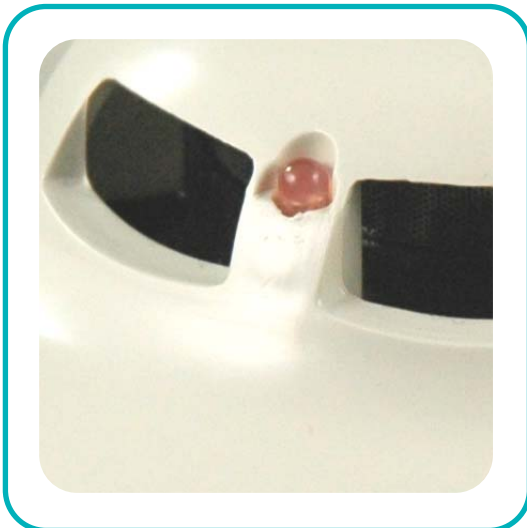

Model ALG-EN is a Photoelectric Smoke Sensor, which is fully compatible with Hochiki's ESP Analogue Addressable Protocol. The ALG-EN is available in ivory, white or black, the black version (with matching black base) is ideal for nightclubs and cinemas where attention to aesthetics is required.

The ALG-EN incorporates Hochiki's unique High Performance Chamber Technology removing the need to use Ionisation Smoke Sensors in the majority of applications. This also allows the sensor threshold level to be increased, thereby improving the signal to noise ratio and reducing susceptibility to false alarms.

The smoke chamber is easily removed or replaced for cleaning and utilises a unique improved baffle design which allows smoke to enter the chamber whilst keeping out ambient light.



- ▶ Removable, High Performance chamber
- ▶ Twin fire LEDs allow 360° viewing
- ▶ Locking mechanism (sensor to base)
- ▶ Variable sensitivity
- ▶ Electronically addressed
- ▶ Non-pulsing feature provided by control panel*
- ▶ Approved by LPCB & VdS

**control panel compatibility required*



DIMENSIONS

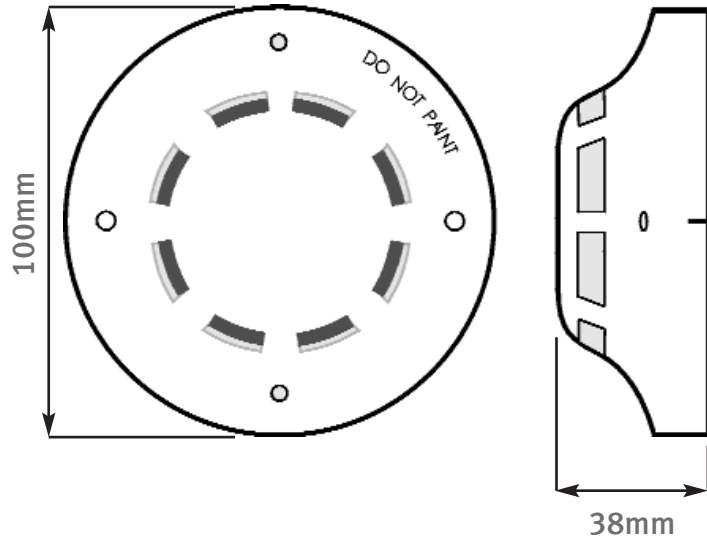

WIRING

KEY: A Loop +ve, B Loop -ve, C Cable Screen

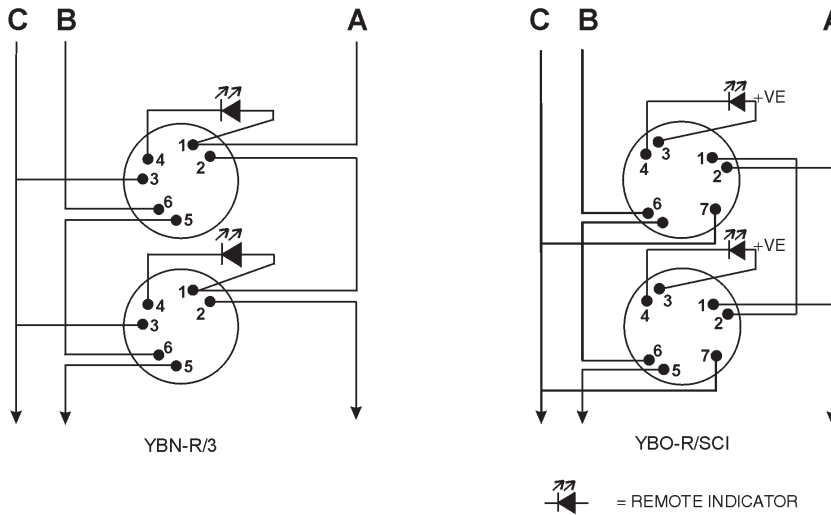

SPECIFICATION

Ordering Codes	Sensor Replacement Chamber	ALG-EN / ALG-EN(WHT) / ALG-EN(BLK) SLV/ALK REPLACEMENT CHAMBER
Operating Voltage		17 - 41V d.c.
Low Power Mode (typ)		120µA
Quiescent Current (typ)		400µA
Alarm Current (controlled by CIE)		9.1mA (excluding remote indicator)
Transmission Method		Digital Communications Using ESP
Operating Temperature Range		-10°C to + 50°C
Storage Temperature Range		-30°C to + 60°C
Maximum Humidity		95% RH - Non Condensing (at 40°C)
Ingress Protection Rating		IP42
Colour / Case Material		Ivory, White or Black / ABS
Weight (g)		90 (excluding base)
Compatible Bases		YBN-R/3, YBO-R/SCI, YBO-BS, YBO-BSB
Base Heights (mm)		8 13 43 43
Base Fixing Centres (mm)		48 ~ 74
Approvals		LPCB EN54: Part 7 VdS EN54: Part 7 (G208037)

HOCHIKI EUROPE (UK) LIMITED
 Grosvenor Road, Gillingham Business Park,
 Gillingham, Kent, England ME8 0SA
 Telephone: +44 (0)1634 260133
 Facsimile: +44 (0)1634 260132
 e-mail (UK): sales@hochikieurope.com
 e-mail (Non UK): export@hochikieurope.com
 www.hochikieurope.com



Quality System
 Certificate No. 164
 Assessed to ISO9001



Environmental Management System
 Certificate No. EMS 286
 Assessed to ISO 14001 : 1996

Hochiki Europe (UK) Ltd. reserves the right to alter the specification of its products from time to time without notice. Although every effort has been made to ensure the accuracy of the information contained in this document it is not warranted or represented by Hochiki Europe (UK) Ltd. to be a complete and up-to-date description.

PART No. 9-5-0-376/ISS1/JUL08